



Forsyth County Procurement

Donna H. Kukarola, CPPO, CPPB, Director

July 10, 2020

ADDENDUM #5

RFP 20-78-1620

For: Providing all labor, equipment and materials for the construction of a new Juvenile Justice Center at 875 Lanier 400 Parkway, Cumming, GA 30040. Project includes a multi-phased site development, demolition of existing motel structures and construction of new 62,000 square foot Juvenile Court building.

This addendum supersedes and supplements all portions of the bidding documents and becomes part of the contract documents for the above-referenced project.

Where any item called for in the specifications or indicated on the drawings is supplemented hereby, the original requirements shall remain in effect.

Where any original item is amended, voided or superseded hereby, the provision of such item not so specifically amended, voided or superseded shall remain in effect.

PART 1 - Prebid Questions Received (response in *bold italics*)

1. We are wondering that if there are models (Arch, MEP) available for us to look at for this project? Revit or Navisworks would be fine.
 - a. **RESPONSE: We will share our models with the awarded contractor. We will require a release to be signed to share the models.**
2. In addendum#2 stated we have to come up with our own construction master schedule. Please provide the date can we assume to mobilization.
 - a. **RESPONSE: As this is a Proposal, the Selection Committee will review all submittals, it is anticipated a short list will be developed and interviews held with recommendation being taken to the Board of Commissioners by September 8, 2020, thus probable start date would be in October 2020.**
3. July 23 at 2:05pm is not the award date, correct?
 - a. **RESPONSE: Correct, this is when names of submitting firms will be read aloud.**
4. Yes, Add.#2 and the Bid Form was reviewed. It doesn't contain any pricing breakdown. In the RFP, p.10, Item #7 says that we are to provide a "detailed cost breakdown" for the entire project. Typically the owner provides a form showing how they would like the pricing broken down. Is/will there be a separate form containing these



Forsyth County Procurement

breakdowns that we are to use? Or can more information be provided how we are to breakdown our pricing for the RFP?

- a. **RESPONSE: *It's up to the General Contractor to determine how this information is formatted and presented in proposal.***
5. I would like to request more clarification regarding the Note on drawing CS-1.01 calling for a full-scale mock-up of a single courtroom:
 - a. Is this mock-up to be completed prior to the project framing and enclosure?
 - i. **RESPONSE: *Yes.***
 - b. Where will this mock-up be located as the court rooms are approximately 42' x 38' in size?
 - i. **RESPONSE: *Temporarily on the unfinished level 200 Floor.***
 - c. Are the temporary walls mentioned at the perimeter of the mock-up area?
 - i. **RESPONSE: *Perimeter walls are required but can be metal studs with single sided unfinished GWB***
 - d. How tall are the mock-up walls?
 - i. **RESPONSE: *Perimeter walls to be 12' tall***
 - e. What finishes will be required (paint, flooring, etc.)?
 - i. **RESPONSE: *No finishes are required***
 - f. Can more information be provided on the required mock-ups for the Courtroom, Cells, and Security Openings (items/divisions required, location of mock-ups, etc.)?
 - i. **RESPONSE: *See responses 5a through 5e for the mock up courtroom. No mock up is required for the cells.***
6. Demolition Note 5A on C031 calls for a 2-story block wall at the portion of the existing building that remains during Phase 2. The note references the architectural and structural drawings for details, but I cannot find this information. Please provide these details.
 - a. **RESPONSE: *General contractor is to hire a shoring engineer to sequence demolition. Reference contract documents and specifications. See also S-0.01, Contractor's Notes, Note 8.***
7. Please clarify which are Buildings A and B as mentioned in the Shoring Note on drawings C030 – C032
 - a. **RESPONSE: *Building A is the existing courtroom building; Building B is the adjacent building to be removed in phase 2.***
8. In spec 31 20 00 – 3.3 is states that no explosives are to be used while some unit prices have Blast Excavation. Can more information be provided about this?
 - a. **RESPONSE: *Provide unit price for blast excavation. The Owner's prerogative if they so choose to entertain method.***
9. Can more information be provided for what Alternate #2 requires?
 - a. **RESPONSE: *Contract Documents identify scope of Alternate #2.***
10. Can a budget number be provided for this project?
 - a. **RESPONSE: *The total project budget is \$19,900,000 as approved by the Forsyth County Board of Commissioners.***



Forsyth County Procurement

11. Spec 08 44 13 – 2.05 is for sunshades. Are these the same sunshades that are for Alternate #1? If not, can more information be provided about the sunshades for Alternate #1?
 - a. **RESPONSE: Correct**
12. Spec 01 4533 – 1.05 states that the owner will provide testing shown on the “Schedule of Special Inspection Services”. Although concrete is shown on the schedule, spec 03 3000 – 1.1, C, 1 says that the contractor is to pay for the testing. This is also the case for other divisions such as Steel. Can more information be provided on what testing needs to be provided by the contractor?
 - a. **RESPONSE: Remove the requirement for the contractor to pay for the special inspections in specifications. Sheet S-0.20 indicates that the owner or owner's agent is to engage the inspection and testing agents.**
13. Will any specifications be provided for the Rammed Aggregate Piers?
 - a. **RESPONSE: Pre contract documents, Rammed Aggregate Pier specifications will need to be provided by the geotechnical engineer in order to meet their specified criteria for bearing capacity. Please reference General Notes Sheet S-0.01, Foundation Notes, Note 1.**
14. Request for product approval - Eco|Space, Barrier System
 - a. **RESPONSE: Approved, must comply with specifications**
15. Request for product approval - Scranton Products - locker/partition products
 - a. **RESPONSE: Approved, must comply with specifications**

COMMENTS FROM SITE VISIT 7/7/2020:

- a) RFP closes July 23rd, 2020 at 2:00 p.m. All proposals must be received by this date/time by the Forsyth County Procurement Department
- b) Reminder, this is a Request for Proposal -- selection criteria is included in our documents.
- c) Phasing of the project is exceptionally important as Court will continue during the demolition/construction
- d) Coordination with the County is exceptionally important because of the continued operations
- e) Power continuity of the existing courthouse is another factor to be considered
- f) Existing secure parking must remain functional until new courthouse and new parking is secured
- g) Demolition, any/all materials that can be recycled shall be

PART 2 – Changes to Drawings

2-1 Sheet S-0.01 GENERAL NOTES:

1. Modify No. #08 under CONTRACTOR'S NOTES.



Forsyth County Procurement

2. Reference sheet S-0.01 GENERAL NOTES revised under addendum #05 dated 07/10/2020.

2-2 Sheet AS-1.02 ARCHITECTURAL SITE DETAILS:

1. Modify 9/AS-1.02 FLAGPOLE PLAN.
2. Reference sheet AS-1.02 ARCHITECTURAL SITE DETAILS revised under addendum #05 dated 07/10/2020.

PART 3 – Changes to Specifications (changes are in *bold and italicized*)

3-1 Specification Section 03 3000 CAST-IN-PLACE CONCRETE:

1. Revised sentence 1.1.C.1.
2. Reference Specification Section 03 3000 CAST-IN-PLACE CONCRETE revised under addendum #04 dated 07/10/2020.

3-2 Specification Section 05 3000 STEEL ROOF DECKING:

1. Revised sentence 1.5.A.
2. Reference Specification Section 05 3000 STEEL ROOF DECKING revised under addendum #05 dated 07/10/2020.

END OF ADDENDUM NO 5

SECTION 03 3000 — CAST-IN-PLACE CONCRETE

PART 1 - GENERAL

This section covers cast in place concrete and all related items for cast in place concrete, including form work, reinforcing and finishes.

1.1 RELATED DOCUMENTS

- A. All work hereunder shall comply with portions of the following industry standards except as called for otherwise herein:
1. American Concrete Institute (ACI):
 - a. 117 10 Specification for Tolerances for Concrete Construction and Materials
 - b. 211.1 Standard Practice for Selecting Proportions for Normal and Heavyweight Mass Concrete
 - c. 211.2 Standard Practice for Selecting Proportions for Structural Lightweight Concrete
 - d. 301 10 Specifications for Structural Concrete
 - e. 304R 00 Guide for Measuring, Mixing, Transporting and Placing Concrete
 - f. 305R 10 Guide to Hot Weather Concreting
 - g. 306R 10 Guide to Cold Weather Concreting
 - h. 306.1 90 Standard Specification for Cold Weather Concreting
 - i. 309R 05 Guide for Consolidation of Concrete
 - j. 315 99 Manual of Standard Practice for Detailing Reinforced Concrete Structures
 - k. 318 11 Building Code Requirements for Reinforced Concrete
 - l. 347 04 Guide to Formwork for Concrete
 - m. SP 4 Formwork for Concrete
 2. U. S. Department of Commerce, NBS, Voluntary Product Standard:
 - a. PS 1 95 Construction and Industrial Plywood
 3. American Society for Testing and Materials (ASTM):
 - a. A 615 Standard Specification for Deformed and Plain Billet Steel Bars for Concrete
 - b. A 185 Standard Specification for Welded Steel Wire Fabric for Concrete Reinforcement
 - c. C 31 Standard Practice for Making and Curing Concrete Test Specimens in the Field
 - d. C 33 Standard Specification for Concrete Aggregates
 - e. C 39 Standard Test Method for Compressive Strength of Cylindrical Concrete Specimens
 - f. C 42 Standard Test Method for Obtaining and Testing Drilled Cores and Sawed Beam of Concrete
 - g. C 94 Standard Specification for Ready Mixed Concrete
 - h. C 143 Standard Test for Slump of Portland Cement Concrete
 - i. C 150 Standard Specification for Portland Cement
 - j. C 172 Standard Practice for Sampling Freshly Mixed Concrete

- k. C 192 Standard Practice for Making and Curing Concrete Test Specimens in the Laboratory
- l. C 260 Standard Specification for Air Entraining Admixtures for Concrete
- m. C 309 Standard Specification for Liquid Membrane
- n. C 330 Standard Specification for Lightweight Aggregates for Structural Concrete
- o. C 494 Standard Specification for Chemical Admixtures for Concrete
- p. C 496 Standard Test Method for Splitting Tensile Strength of Cylindrical Concrete Specimens
- q. C 567 Standard Test Method for Density of Structural Lightweight Concrete
- r. C 1077 Standard Practice for Laboratories Testing Concrete and Concrete Aggregate for Use in Construction and Criteria for Laboratory Evaluation
- s. D 4887 Standard Practice for Preparation of Viscosity Blends for Hot Recycled Bituminous Materials
- t. D 1751 Standard Specification for Preformed Expansion Joint Filler for Concrete Paving and Structural Construction (Nonextruding and Resilient Bituminous Types)
- u. E 329 Standard Specification for Agencies Engaged in Construction Inspection, Testing, or Special Inspection
- 4. Concrete Reinforcing Steel Institute (CRSI):
 - a. 2009 Manual of Standard Practice
 - b. 2011 Placing Reinforcing Bars
- 5. Building Codes under which this project is designed and shall be built:
 - a. International Building Code, (Latest) Adopted Edition.

B. Products furnished under this section shall be of domestic origin and manufacture.

C. Concrete Testing

- 1. Laboratory shall be independent, acceptable to Architect, and comply with ASTM E 329. ~~Payment for mix design, verification and remedial testing shall be made by the Contractor. Payment for all other testing shall be made by the Contractor.~~
- 2. Mix design shall be determined by the laboratory on the basis of field experience or trial verified batches in accord with ACI 318, Article 5.2 and 5.3. Trial batches to verify mix design, compressive strength, and workability under severe weather field conditions using materials proposed for production concrete by Contractor shall be made and evaluated by the laboratory.
- 3. Concrete testing shall require one set (three cylinders) of cylinders from same batch for each 150 cubic yards or fraction thereof for concrete in each day's placement for each class and mix design. Each set of three cylinders shall have a numerical designation and each cylinder an alphabetical sub designation. Thus the first set of three cylinders shall be numbered 1A, 1B and 1C.
 - a. One cylinder shall be tested at 7 day age.
 - b. Two acceptance cylinders are compressive test cylinders molded in the field, stored and cured in the field for the first 24 hours after molding, and thereafter in laboratory until time of testing. Average breaking strength at 28 days of 2 acceptance cylinders from a set will comprise a test. Tests shall be in accordance with ASTM C39.
 - c. Evaluation of the 28 day compression test results shall be in accord with ACI 318, section 5.6 and ACI 301, Section 17.2.

4. Contractor's duties relative to testing shall include the following:
 - a. Secure and deliver to laboratory representative samples of materials he proposes to use and which are to be tested.
 - b. Supply wheelbarrows, shovels, mixing boards and shaded workspace for field testing of concrete and molding test cylinders in field. Provide stable, insulated storage boxes equipped with controlled heat for storage of cylinders in first 24 hours after molding in accord with ASTM C31.
 5. Field testing shall be performed by qualified personnel. Field testing consists of sampling fresh concrete; making compression test specimens; performing tests for slump; protecting and initially curing test specimens for first 24 hours; transporting or preparing and shipping test specimens to laboratory; and, completing field test data sheet for each set of test specimens and transmitting same to laboratory. Data sheet shall show information required to these specifications, and name of individual responsible for performance of field tests and submission of associated data.
 6. Sample specimen concrete at discharge end of pipe if pumped. Do not use aluminum pipes.
- D. Use of laboratory testing services shall in no way relieve Contractor of his responsibility to furnish materials and construction in full compliance with Contract Documents.
- E. Tolerances shall comply with ACI 117.
- F. The laboratory shall send one copy of all tests to the Architect's Structural Engineer, one to the Architect, one to the Contractor and one to the ready mix plant. Concrete test reports shall include slump test and state where the concrete was used in the structure.

1.2 PROCEDURES

- A. If the evaluation of the compressive tests indicates that the concrete has failed to meet the specified strength, core tests shall be made of the in place concrete. The location and number of such tests to be at the Architect's direction. Tests shall be made by a laboratory approved by the Architect. Tests shall be paid for by the Contractor.
- B. If the core tests fail to verify the strength specified, the Architect shall effect one of the following procedures:
 1. Have the Contractor remove and reconstruct that portion of the structure found to be defective.
 2. Accept the concrete in place and issue a change order as set forth in the General Conditions of these specifications.

1.3 SUBMITTALS

- A. Concrete ingredients to laboratory.
- B. Laboratory reports of aggregate tests, verification of mix design and tests on field concrete, three copies each to the Architect.

- C. Submit to Architect plans and procedures for cold weather concreting in accordance with ACI 306.1.
- D. Submit manufacturers' literature for use and properties of each for admixtures, curing materials, hardeners, non slip aggregates, bonding materials, joint fillers and sealers, proposed for use.

1.4 SHOP DRAWINGS

- A. The Contractor shall furnish drawings and details for the fabrication and placing of reinforcing steel when used with the contract drawings. Shop drawings shall show complete fabrication, bending, and placement of reinforcing. Comply with ACI 315 and CRSI Manuals; and indicate bar schedules giving bar sizes, dimensions and splicing details, tie and stirrup spacing, diagrams of bent bars, and arrangements and assemblies as indicated on the drawings. All schedules shall be same as or similar to those shown on the Contract Drawings.
- B. All drawings and details must be checked and show the initial of the checker before they are submitted for approval.
- C. Review of shop drawings by the consultant does NOT relieve the Contractor from full responsibility of complying with the Contract Documents.
- D. All drawings for review must be submitted in one (1) reproducible set and two (2) sets of copies. One (1) set of reproducible shall be returned to the Contractor marked as follows:
 - 1. "No Exceptions Taken" Indicates the drawings have been reviewed for general conformance with contract documents and no exceptions have been taken.
 - 2. "Exceptions Noted" Indicates the drawings have been reviewed for general conformance with the contract documents and that exceptions have been taken.
 - 3. "Exceptions Noted Resubmit" Indicates the drawings have been reviewed for general conformance with the contract documents After items to which exceptions have been taken are corrected, Contractor shall again submit copies for review.
 - 4. "Resubmit" Indicates the drawings have been reviewed for general conformance with the contract documents and are too incomplete or in an unacceptable condition for review. A notation will be made on the shop drawings as to the exceptions taken. Drawings shall be revised and resubmitted for review before proceeding with the work.
 - 5. In case exceptions are noted on one sheet which affects details on other sheets, the exception is to be taken as applying to all such other details.
 - 6. Review of shop drawings by the Architect or Engineer shall not constitute an authorization or approval of a change to the contract. Changes from the contract documents must be made in writing.

1.5 JOB CONDITIONS

- A. Severe Weather Concreting: Unless protection is provided, concrete shall not be placed during rain. Rainwater shall not be allowed to increase mixing water or to damage surface finish.
 - 1. Cold Weather: Only the specified non corrosive, non chloride accelerator shall be used. Calcium chloride, thiocyanates or admixtures containing more than 0.05% chloride ions are not permitted.

2. Hot Weather: Provide methods of lowering temperature of concrete ingredients so that temperature of concrete when placed does not exceed 90 degrees F. When atmospheric temperature is 80 degrees F. and above, or during other climatic conditions which will cause too rapid drying of concrete, make arrangements before start of concrete placing for installation of wind breaks or shading, and for spraying, sprinkling, or moisture retaining covering. Sprinkle subgrade and forms with water before placing concrete. Curing shall start as soon as practicable to prevent evaporation of water and forms shall be kept wet. Protect flat work from dry winds, direct sun and high temperature. Protect concrete continuously for concrete curing period. Follow recommendations of ACI 305R.
- B. Deliver reinforcement to project site bundled, tagged and marked. Use metal tags, indicate bar size, length and information corresponding to designation shown on placement drawings. Store at site to prevent damage and accumulation of dirt or rust.
- C. Inspect job for conditions which would prevent execution of this work as specified. Do not proceed until such conditions are corrected.

PART 2 - MATERIAL

- A. All cement shall be Type 1 and must meet ASTM C150.
- B. Fine aggregates shall meet ASTM C33.
- C. Coarse aggregate for normal weight concrete shall conform to ASTM C33 and shall be sized within the limits as established by Table 11, 1" to #4. Coarse aggregate for "pea gravel" concrete for concrete block fills shall be #7. Coarse aggregate for structural lightweight concrete shall conform to ASTM C330.
- D. Admixtures shall comply with ASTM C494, Types A, D, E, F or G and not contain more than 0.05% chloride ions.
- E. Water shall be clean, fresh, free from oil, acid, organic matter or deleterious substances.
- F. All concrete shall be proportioned by weight so as to give an ultimate compressive strength at 28 days as called for on plans. Proportions of all concrete shall be determined by a laboratory approved by the Architect.
- G. The mix shall be so proportioned that the average strength of the laboratory cured specimen, as well as the average of any three consecutive strength tests, shall be equal to or greater than the strength specified on plans, and no test shall have a value less than the specified strength less 500 psi.
- H. Minimum cement content for regular concrete shall be as follows:
 1. 3,000 psi concrete 498# (5.3 bags)
 2. 3,750 psi concrete 592# (6.3 bags)
 3. 4,000 psi concrete 611# (6.5 bags)
 4. 5,000 psi concrete 686# (7.3 bags)

5. 6,000 psi concrete 761#(8.1 bags)
6. 3,000 psi lightweight concrete 545# (5.8 bags)
7. 4,000 psi lightweight concrete 677# (7.2 bags)
8. For pump mixes add 47# (0.5 bags) to the above quantities.

- I. The water-cement ratio of the mix shall be established in the design and shall be based on the established relationship between the water-cement ratio and the strength of concrete shall be such as to produce the specified strength of the concrete with the least amount of water consistent with the workability of the mix. Surface water contained in the aggregate shall be included as part of the mixing water in computing the water content. The design shall provide for a slump range of 3" minimum, 5" maximum.
- J. Lightweight concrete shall be so proportioned that the airdry weight will not exceed 120 pcf, and the concrete shall develop an Fsp of not less than 6.3.
- K. All reinforcing bars shall comply with ASTM A615, Grade 60.
- L. Welded wire fabric shall comply with ASTM A185.
- M. Support accessories shall comply with ACI 315 and CRSI Manual. Accessories over earth shall be precast concrete block bar supports.
- N. Horizontal reinforcing for block walls shall be a welded wire "ladder type". Horizontal wires shall be deformed #9 and transverse wires shall be #9 at 15" o.c. All wires to meet ASTM A82.

2.2 FORM MATERIAL

- A. Plywood shall be PS 1 (Concrete Form) Plywood, Class 11, exterior grade, mill oiled and edgesealed.
- B. Form coating shall not stain or soften concrete, shall serve as a parting compound or chemical releasing agent to prevent sticking of concrete to forms, and shall act as sealer to protect coating on forms.
- C. Round column forms shall be Seamless Sonotube by Sonoco Products Co.
- D. Control joints for slabs on ground shall be 24 gauge, galvanized, pre shaped, keyed type. Joints shall be ½" less in depth than the slab. Joints shall be held in place with 1" x 1/8" ribbed stakes at 1' 0" o.c. on the female side. The male side of the joint shall be greased or sprayed with a bond breaker. Approved joints are as follows:
 1. Burke Concrete Accessories, Inc.
 2. Jahn Concrete Forming Products
 3. Keykold, Inc.
- E. Fill for slabs on grade shall be #57 stone, 4" thick where shown on drawings.

2.3 CURING COMPOUNDS & SEALERS

- A. Curing compounds shall meet ASTM C309 89 Type 1.
- B. The following curing compounds are approved.
 - 1. L & M CURE L & M CONSTRUCTION CHEM.
 - 2. KUREZ DR THE EUCLID CHEMICAL COMPANY
- C. Other curing compounds can be used provided that the Contractor furnish the Architect a letter of certification from the manufacturer stating that the proposed curing compound will allow the proper bonding of paints, resilient floor covering, sprayed on finishes, waterproofing materials, applied ceramic tiles, quarry tiles or marble. The General Contractor is responsible for cleaning the slab and removing any material from the curing compound that will not allow the proper bonding indicated above.
- D. After the Contractor has selected the compound he elects to use, and two weeks prior to the date he has scheduled to apply it, a copy of the manufacturer's recommendations for applying the compound shall be furnished to the Architect.
- E. The following sealers are approved:
 - 1. DRESS & SEAL 30 L & M CONSTRUCTION CHEM.
 - 2. MASTER SEAL MASTER BUILDERS
 - 3. KURE N SEAL SONNEBORN

2.4 CURING MATERIALS

- A. Absorptive Cover: Burlap cloth made from jute to kenaf, weighing approximately 9 oz. per sq. yd. complying with AASHO M182, Class 3; or 2" of clean sand.
- B. Moisture Retaining Cover: One of the following is acceptable:
 - 1. Waterproof paper, ASTM C 171, Type 1 or 2
 - 2. Polyethylene sheeting, AASHO M 171
 - 3. Polyethylene coating burlap

2.5 BONDING & REPAIR MATERIALS

- A. Bonding Compounds: Rewettable: The compound shall be a polyvinyl acetate type, "Euco Weld" by The Euclid Chemical Co. or "Weldcrete" by The Larsen Co. Use only in areas not subject to moisture.
- B. Non Rewettable; Polymer modified, bonding compound, "Euco Bond" by The Euclid Chemical Company or approved equal.
- C. Epoxy Adhesive: The compound shall be a two (2) component, 100% solids, 100% reactive compound suitable for use on dry or damp surfaces, "Euco Epoxy No. 452MV or No. 620" by The Euclid Chemical Co. or "Sikadure Hi Mod" by The Sika Chemical Corp.

- D. Polymer Patching Mortar: Free flowing, polymer modified cementitious coating, "Euco Thin Coat" by The Euclid Chemical Co. or "Sikatop 121" by The Sika Chemical Corp.
- E. Repair Topping: Self leveling, polymer modified high strength topping, "Thin Top SL" by The Euclid Chemical Co.
- F. Free flowing, self leveling, pumpable cementitious base compound, "Flo Top" by The Euclid Chemical Co.

PART 3 - EXECUTION

3.1 FORMS

- A. The design and engineering of the formwork, as well as its construction shall be the responsibility of the Contractor. Except as specifically called for otherwise herein, all formwork shall meet the "ACI Standard Recommended Practice for Concrete Formwork (ACI 347R 88)".
- B. The formwork shall be designed for the loads and lateral pressure outlined in Chapter 2, paragraph 2.2 of ACI 347R. Design considerations and allowable stresses shall meet paragraph 2.3 of the above reference and the requirements of the AISC Ninth Edition for Steel and the AITC Third Edition for Wood.
- C. Formwork shall be constructed so as to insure that the concrete surfaces will conform to the tolerances given in paragraph 3.3 "Recommended Practice for Concrete Formwork" (ACI 347R).
- D. Formwork shall be constructed to the shape, lines, grades and dimensions indicated on the drawings, and shall comply with ACI 301, 347, SP 4 and the "Quality Criteria" specified.
 - 1. Provide screeds at required elevations to result in surfaces meeting project specification provisions.
- E. Before placing reinforcement, apply form coating in accord with manufacturer's instructions to surface of forms to be in contact with concrete.
- F. Dampen subgrade at slabs on ground immediately before placing concrete.
- G. Removal of Forms:
 - 1. Under ordinary weather conditions forms may be removed in 2 days, providing concrete is not injured by so doing.
 - 2. Under no circumstances shall wood be buried in fill or left in contact with earth.
- H. Re Use of Forms:
 - 1. Clean and repair surfaces of forms that are to be reused except split, frayed, delaminated, patched or damaged form facing material will not be acceptable.
 - 2. Form coating shall be reapplied to concrete contact form surfaces as specified above.

- I. Construction Joints:
 - 1. Remove plastic caps from preformed steel forms no sooner than 24 hours after casing concrete. Fill void with epoxy joint filler or elastomeric sealant as indicated on the drawings.

3.2 SITE PREPERATION

- A. Where excavations exceeding a depth of five feet are to be made to install the foundations or any part of the structure of this building, or any retaining walls on the site, the backslope of such excavation shall be at an incline not exceeding one vertical to one and one half horizontal unless such backslope is sheeted and braced. If sheeting and bracing is to be provided, such sheeting and bracing shall be designed by an engineer registered in the state in which the project is being built. Such sheeting and bracing shall be designed to resist the pressures presented on age's 14 22 to 14 25 of the CRSI Design Handbook, 1978 Edition, unless more specific pressures are determined by a registered soils engineer. The cost of such design work shall be paid for by the Contractor.

3.3 REINFORCEMENT

- A. Fabrication shall be in accord with ACI 315 and CRSI Manual. Bars shall be bent cold to shapes and dimensions indicated within tolerances of ACI 117.
- B. Clean bars to remove rust and mill scale, earth and materials which reduce or destroy bond with concrete. Place reinforcement and supports in accord with ACI 315 and CRSI Manual. Support and tie reinforcement to prevent its displacement by construction loads or placement of concrete.
- C. Reinforcement shall be secured in position in compliance with ACI 117 to allow 3" clear to sides and bottom and 2" clear to top of concrete slab surface. Welded wire fabric shall be placed 1" clear to top of concrete slab surface. Tie dowels in place before concrete is placed. Do not "stick" dowels.
- D. Contract drawings shall take precedence over Contractor's working drawings unless otherwise authorized by the Architect. Contract drawings shall be referred to by the steel setter for details governing placing.
- E. Reinforcing must be correct in length and size and bent in accordance with the plans and structural drawings. It must be located in forms and wired together with clearance to provide concrete protection as noted herein.
- F. No splicing of main reinforcing steel will be permitted unless shown otherwise on plans. Bars marked continuous shall be lapped 30 diameters at splices and at corners, corner bars shall be provided.
- G. Concrete covering for reinforcing steel shall be 1½" for lintels and walls and 3" for footings.

- H. Wire mesh, where called for on the drawings, shall be lapped a minimum of 6" and wired together at both side and end laps.

3.4 PLACEMENT OF BLOCK WALL REINFORCEMENT

- A. The Contractor's attention is called to the sequence of installation of reinforcement in the block work. Should masonry work be permitted to proceed beyond such points as will permit the installation of the reinforcement and the filling of the cells, there will be no alternative but to remove those portions of the wall that prohibit the installation of the reinforcement. All such work of removal and rebuilding shall be done at no expense to the Owner.
- B. Dowels of the same size as the vertical wall reinforcing shall be set in footings at each vertical reinforcing bar. After wall has been laid up to the course designated on plans, the vertical reinforcing shall be inserted in the hollow block cell. The cell in which the reinforcing occurs shall then be filled with the "pea gravel" concrete. The vertical bar shall be "worked" to consolidate the concrete.
- C. Extension of vertical bars for laps and for anchorage in top bond beams shall be as shown in wall sections on contract drawings. Minimum lap of vertical bars shall be 2' 0".
- D. Where designated on drawings, a U block bond beam shall be laid. Openings in the bottom of the block shall be made to permit the vertical reinforcing to extend.
- E. At the U block at the roof the vertical bars shall be bent over into the top of the U block.
- F. Horizontal reinforcing shall be placed in the U block; all anchor bolts or other anchoring devices set and the U block bond beam cast with "pea gravel" concrete.
- G. At control joints and expansion joints in masonry walls the horizontal reinforcing in the U block bond beams shall be discontinuous.
- H. A "ladder type" welded wire block wall reinforcing shall be installed horizontally in every other block course. Reinforcing shall be crossed at corners and lapped 12" at splices. Reinforcing shall be discontinuous at control joints and at expansion joints.
- I. See Concrete Masonry Section for other reinforcing and anchoring devices to be used in block work.

3.5 PROPORTIONS

- A. All concrete shall be proportioned, using ACI 211, by weight producing an ultimate compressive strength at 28 days as called for.
- B. The mix shall be so proportioned that the average strength of the laboratory cured specimen, as well as the average of any three consecutive strength tests, shall be equal to or greater than the specified strength. No test shall have a value less than 500 psi under the prescribed strength.

- C. Minimum cement content shall be as follows: for 3,000 psi concrete 498# (5.3 bags).
- D. The design mixes shall provide for a slump of 3" minimum, 5" maximum.
- E. Except for "pea gravel" concrete, the following amount of water reducing admix shall be provided in accordance with the manufacturer's recommendations for each bag of cement in the mix: Air temperature below 70 deg F. 3 oz. of Master Builder's Pozzoloth 300N; American Admix Corporation's Lubricon 300; Protex PDA 25XL; 2 oz. of Sika Chemical Company's Plastocrete; Gifford Hill's PSI Normal; Castle Chemical Corporation's Chemstrong A or Construction Chemical Company's Trisene N. or W. R. Grace Company's WRDA 79. Air temperature above 70 deg F. 3 oz. of Master Builder's Pozzoloth 300R; American Admix Corporation's Lubritard; Protex PDA 25R, Sika Chemical Company's Plastocrete; Gifford Hill's PSI Retarder; Castle Chemical Corporation's Chemstrong R or Construction Chemical Company's Trisene R or W. R. Grace Company's WRDA 79.

3.6 PREPERATION

- A. Before placing of any concrete, the footing trenches shall be drained of water, mud film removed and any loose dirt lifted out.
- B. Before placing concrete in any forms, the forms shall be cleaned and all debris shall be removed. All reinforcing shall be checked to be sure that no reinforcing is touching the form.
- C. Before placing any concrete, it shall be determined that all work that is to be built into the concrete work is located and installed. All items shall be so placed as not to interfere with the reinforcing steel. Wood board forms shall be soaked with water just before the concrete is poured.
- D. Workman shall be designated to lift mesh reinforcing off the ground or the bottom of forms as concrete is placed.
- E. Special measures shall be taken in both severe cold and hot weather and shall be in accordance with ACI Recommended Practice (ACI 306R and ACI 305R).

3.7 PRODUCTION

- A. Mixing shall be achieved by using equipment and methods in accordance with provisions of ASTM C94; however, concrete production may be on or off site. Ready mixed concrete purchased from a local producer may be used.
- B. Delivery tickets shall be furnished with each load of concrete. Ticket shall show class and strength, pounds of cement, size of course aggregate, time batched, slump ordered and amount and type of admixtures.

3.8 CONVEYING

- A. Place concrete employing experienced crew with equipment to place in a continuous unbroken operation from beginning to end. Convey concrete from mixer to place of final deposit by methods which will prevent separation or loss of materials.
- B. Vehicles shall be equipped with pneumatic tires.
- C. Runways shall not be supported on reinforcement or fresh concrete.
- D. Equipment shall be in first class operating condition, cleaned before beginning and cleaned at frequent intervals during placing concrete.

3.9 CASTING

- A. Deposit concrete as nearly as practicable in its final position to avoid segregation due to rehandling or flowing. Concreting shall be at such rate that concrete is at all times plastic and flows readily into forms. No concrete shall be deposited that has partially hardened or been contaminated by foreign material, nor shall retempered concrete be used. In no case shall concrete be used when elapsed time after addition of water and cement to batch exceed one hour. Concrete shall not be dropped freely where reinforcing will cause segregation nor shall it be dropped freely more than ten (10) feet for concrete containing the high range water reducing admixture (superplasticizer) or five (5) feet for other concrete.
- B. When concreting is once started, it shall be carried on as a continuous operation until placing is complete. The top surface shall be finished to a true plane, sloping to drains as shown.
- C. Consolidate concrete by vibration, spading, rodding or torking so that concrete is worked around reinforcing, embedded items, and into corners of forms, eliminating air or stone pockets which may cause honeycombing, pitting, or planes of weakness. Internal vibrators shall be used in accord with Section 7.1, ACI 309. Over vibrating and use of vibrators to transport concrete within forms shall not be allowed. Vibrators shall be inserted and withdrawn at many points, from 18" to 30" apart, from 5 to 15 seconds duration. A spare vibrator shall be kept on job site during concrete placing operations. Follow recommendations of ACI 309.
- D. Internal type mechanical vibrators and hand spading shall be used to consolidate the concrete and produce a dense concrete free from voids and honeycombs. Care shall be taken that vibration is not applied long enough to separate the ingredients.
- E. All floor slabs shall be screeded to an even surface by the use of a straight edge and screeding strips set at the level called for on plans. Screeds shall be of type and so arranged as not to interfere with the top slab steel. Finish is specified in a following section.
- F. Tolerances in finish to concrete floor and roof slabs shall comply with ACI 302, "Guide for Concrete Floor and Slab Construction".
 - 1. Floor slabs to remain exposed or to receive contact floor covering, thin set tile or sealer and dustproofer. Ff 25/F1 20 (F1 17 for elevated slabs).

2. Floor slabs to receive setting bed or metallic waterproofing and achieve an Ff 20/FI 17 to tolerance.
 3. Roof slabs shall achieve an Ff 20/FI 17 tolerance.
 4. Exterior Slabs: Shall achieve an Ff 20/FI 17 tolerance.
- G. Joints in slabs or beams construction shall be bulkheaded vertically and located at the center of the span. In the event an intersecting member occurs at the center of the span or it is not possible to locate the joint at the center of the span, special provision will have to be made for shear. The Contractor shall obtain instructions from the Architect as to what provisions to make.
- H. Before depositing the new concrete on or against concrete that was hardened, the forms shall be retightened, the surface of the hardened concrete roughened, cleaned of foreign matter and laitance and moistened with water. To insure mortar at the juncture of the hardened and newly deposited concrete the cleaned and moistened surface of the hardened concrete, including vertical and inclined surfaces, shall first be slushed with a coating of neat concrete grout against which the new concrete shall be placed before the grout has attained its initial set. Before starting to place concrete in walls and columns a uniform layer of grout two inches thick shall be placed at the bottom of the forms or on top of the hardened concrete. The grout shall consist of one part cement and two parts sand with enough water to make a thick consistency.

3.10 FINISHING

- A. Floors, including slabs on ground, shall be finished as follows:
1. The surfaces of all concrete shall be worked with a wood float in a manner which will compact the concrete and produce a surface free of depressions or inequalities of any kind. Test for grade (or level) and correct by removing excess or adding and compacting additional concrete
 2. Except where dropped for finish, all floor slabs shall receive steel trowel finish as follows: After screeding, slab shall be woodfloated until hardened to prevent excess fines from working to surface, steel trowel to a smooth surface free from defects. A second steel troweling shall be done producing a plain, hard, dense, finished surface.
 3. Troweling shall not be begun until all surface water has disappeared. The drying of the surface moisture before troweling must proceed naturally and must not be hastened by sacking or dusting on of dry sand and cement.
 4. Floors that are dropped for finish shall be struck off smooth with a woodfloat and broomed with a coarse broom.
 5. On all concrete stair treads & ramps provide abrasive aggregate. Materials shall be applied at the rate of 25 lbs. per 100 sq. ft.
 6. After troweling, all aisles and parking areas shall be broomed as follows:
 - a. Aisles – Medium brooming (perpendicular to traffic flow).
 - b. Parking Area – Light brooming (parallel to traffic flow)
 7. The initial brooming shall be accomplished in the presence of the Owner. Upon acceptance of the brooming operation and technique of the first area, this first area shall become the standard of all like areas. Brooming shall be neat and in straight lines.
- B. Exposed concrete surfaces shall be finished as follows:
1. Surface shall be rubbed smooth with carborundum brick within 36 hours after forms are removed. Surfaces shall be wetted and rubbed until a uniform color and texture is

produced. No cement grout or slush shall be used other than the cement paste drawn from the green concrete itself by the rubbing process.

2. Corners and edges shall be pointed up to present a square appearance.
3. Consolidate concrete surface by final hand troweling operation, free of trowel marks, uniform in texture and appearance. Surface shall achieve an Ff 25/FI 20 (FI 17 for elevated slabs) tolerance. Grind smooth surface defects which would telegraph through applied floor covering system.
4. Apply light broom finish to exterior concrete slabs.

3.11 PROTECTION & CORRECTIVE WORK

- A. Workmen shall not walk on concrete during placing or finishing with any earth or foreign matter on footgear.
- B. All freshly placed concrete shall be protected from damage or injury due to water, falling objects, persons or anything that might mar or injure the finish surface of the concrete. Any surfaces that are damaged shall be removed and replaced with fresh concrete at the expense of the Contractor.
- C. Where concrete or concrete work does not conform to the specifications and where low strength concrete is not permitted to remain in place, procedures and plans covering all work to be rebuilt shall be submitted by the Contractor to the Architect before removal and rebuilding is begun. The cost of such plans, as well as the cost of removal and rebuilding shall be at the Contractor's expense.
- D. Until such time that block walls are tied into floor and roof construction, it shall be the responsibility of the Contractor to secure walls to prevent lateral displacement from wind or other causes.

3.12 CONCRETE CURING & PROTECTION

- A. General:
 1. Protect all concrete from premature drying and excessive cold or hot temperature, and maintain without drying at relatively constant temperature to uniformly provide the hydration of cement and hardening of concrete.
 2. Start initial curing as soon as free water has disappeared from concrete surface after placing and finishing. If surface has dried prior to application, saturate with water. Keep continuously moist for not less than 72 hours.
 3. Begin final curing procedures immediately following initial curing and before the concrete has dried. Continue final curing for at least 168 cumulative hours (not necessarily consecutive) during which the concrete has been exposed to air temperatures above 50 deg. Avoid rapid drying at end of final curing period.
- B. Curing Methods
 1. Cure concrete by moist curing, by moisture retaining cover curing, by liquid membrane curing, by liquid curing hardening compound, or by combinations thereof, as herein specified.

2. Water used in curing shall be free of impurities which could etch or discolor exposed, natural concrete surfaces.
- C. Provide moisture curing by any of the following methods:
 1. Keeping surface of concrete continuously wet by covering with water.
 2. Continuous water fog spray.
 3. Covering concrete surface with specified absorptive cover, saturating cover with water, and keeping absorptive cover continuously wet. Place absorptive cover so as to provide coverage of concrete surfaces and edges, with a 4" lap over adjacent absorptive covers.
- D. Provide moisture retaining cover curing as follows: Cover concrete surfaces with specified moisture retaining cover for curing concrete, placed in widest practicable width with sides and ends lapped at least 3" and sealed by waterproof tape or adhesive. Immediately repair any holes or tears during curing period using cover material and waterproof tape.
- E. Provide liquid curing and sealing compound as follows:
 1. For all exposed interior slabs and troweled slabs receiving mastic applied adhesives or metallic or mineral aggregate hardeners. Exterior slabs, sidewalks, curbs, architectural concrete and any concrete where total resistance to yellowing from ultraviolet light and water exposure is required shall be cured with the specified clear, non yellowing curing and sealing compound.
- F. Cure formed surfaces of concrete, including undersides of girders, beams, supported slabs and other similar surfaces by moist curing with forms in place for full curing period or until forms are removed. If forms are removed, continue curing by methods specified above.
- G. Curing Unformed Surfaces:
 1. Initially cure unformed surfaces, such as slabs, floor topping and other flat surfaces by moist curing. Final cure unformed surfaces, unless otherwise specified, by any of the methods specified above.

3.13 DEFECTIVE CONCRETE FINISHING

- A. Concrete finish which is not true to line and plane, which is not thoroughly troweled and properly surfaced as required, which varies in excess of Ff and Fl requirements, which scuffs or has a rough top surface, except where required, or which does not connect properly to adjoining work, or does not slope to drains, or is not properly cured, will be deemed defective. Remove and replace with proper work and material conforming to the requirements, when so directed by the Architect.
- B. Floors judged by the Architect to be unfit to receive floor covering material shall be brought to required finish by the Contractor at no additional cost to the Owner.

3.14 REPAIR OF DEFECTIVE AREAS

- A. Defective Areas: Concrete which is not formed as shown on drawings or for any reason is out of alignment or level or shows a defective surface, or shows defects which reduce structural

adequacy of member or members, shall be considered as not conforming with the intent of these specifications and shall be removed from job unless Architect grants permission to patch defective work.

1. Permission to repair such areas shall not be considered a waive of Architect's right to require complete removal of defective work if patching does not, in his opinion, satisfactorily restore quality and appearance of surface or structural adequacy of member or members.
- B. Method of Repair: If permission to patch defective areas is granted, the repair shall be done immediately after form removal as follows:
1. Defective areas shall be chipped away to a depth of not less than 1" with edges perpendicular to surface. Area to be repaired and an area at least 6" wide surrounding it, shall be dampened to prevent absorption of water from repair mortar. After surface water has evaporated from area to be repaired, apply the specified bonding compound (rewettable) or latex bonding compound.
 2. Make patching mixture of same material and of same proportions as used for the concrete, except that coarse aggregates shall be omitted and the mortar shall consist of not more than 1 part cement to 2 1/2 parts sand by damp loose volume. White Portland Cement shall be substituted for a part of the gray Portland Cement on exposed concrete in order to produce a color matching the color of the surrounding concrete, as determined by a trial patch.
 3. The quantity of mixing water shall be no more than necessary for handling and placing. Mix patching mortar in advance and allow it to stand, giving it frequent manipulations with trowel without adding water, until it has reached stiffest consistency that will permit placing.
 4. Apply the specified patching mortar after the bonding compound has dried while the bonding grout is still tacky. Consolidate the mortar into place and strike off so as to leave patch slightly higher than surrounding surface. To permit initial shrinkage, it shall be left undisturbed for at least 1 hour before being finished. Patched area shall be kept damp for 7 days. Metal tools shall be used in finishing a patch in a form wall which will be exposed.
 5. Finish repaired surfaces to match the adjacent surfaces.
- C. Tie Holes: After being cleaned and dampened, fill tie holes solid with patching mortar and finish same as in Paragraph B above.
- D. The specified polymer patching mortar may be used in lieu of the bonding compound with prior approval of the Engineer, when color match of the adjacent concrete is not required.
- E. All structural repairs shall be made with prior approval of the Engineer as to method and procedure, using the specified epoxy adhesive and/or epoxy mortar. Where epoxy injection procedures must be used, an approved low viscosity epoxy made by the manufacturers previously specified shall be used.
- F. Leveling of floors for subsequent finishes shall be achieved by use of the specified underlayment material.
- G. Repair Topping: All exposed floors shall be leveled, where required, with the specified self leveling repair topping.

FORSYTH COUNTY JUVENILE COURT BUILDING
FORSYTH COUNTY BOARD OF COMMISSIONERS
CUMMING, GEORGIA

JERICO DESIGN GROUP – 19059

END OF SECTION 03 30 00

SECTION 05 3000 – STEEL ROOF DECKING

PART 1 - GENERAL

1.1 RELATED DOCUMENTS

- A. Drawings and general provisions of the Contract, including General Conditions, Supplementary General Conditions, and Division 01 Specification Sections, apply to this Section.

1.2 SUMMARY

- A. This section covers steel roof deck and all related work.
- B. Related Sections: The following sections contain requirements that relate to this Section:
 - 1. Division 05 Sections “Structural Steel” and Steel Joist Framing”.

1.3 REFERENCE STANDARDS

- A. American Iron and Steel Institute (AISI):
 - 1. SG03-3, Cold Formed Steel Design Manual Set, 2002 Edition
- B. American Welding Society (AWS):
 - 1. D1.3 08, Structural Welding Code Sheet Steel
- C. Steel Deck Institute (SDI):
 - 1. SDI 31 (2007), Design Manual for Composite Decks, Form Decks and Roof Decks
- D. American Society for Testing and Materials (ASTM):
 - 1. ASTM A653/A653M-08, Standard Specification for Steel Sheet, Zinc-Coated (Galvanized) or Zinc-Iron Alloy-Coated (Galvannealed) by the Hot-Dip Process
 - 2. ASTM A1008/A1008M-08a, Standard Specification for Steel, Sheet, Cold-Rolled, Carbon, Structural, High-Strength Low-Alloy, High-Strength Low-Alloy with Improved Formability, Solution Hardened, and Bake Hardenable
 - 3. ASTM E329-08, Standard Specification for Agencies Engaged in Construction Inspection and/or Testing

1.4 SHOP DRAWINGS

- A. All drawings for review must be submitted electronically to the Architect, one master submittal will be returned to the Contractor electronically with each disciplines comments marked in a separate color. Submittals shall include erection drawings, sections, and fabrication drawings. Erection shall not begin until the Contractor has been furnished a copy of the drawings to which no exception has been taken.

- B. The welding washers and welding patterns for attachment of deck to support shall be covered on shop drawings.
- C. Submit detailed drawings showing plan layout of deck panels, anchorage details and every condition requiring closure panels, supplementary framing, special jointing or other accessories.

1.5 INSPECTION AND TESTING

- A. Inspections and tests shall be performed by an independent laboratory complying with ASTM E329 selected and approved by the Owner's Project Manager and by the Architect, and paid by the **Owner**. All material to be furnished shall be subject to inspections and tests in the shop and field.
- B. Inspection and testing shall include deck placement, deck condition and welding.
- C. Reports of inspections and testing shall be made by the laboratory on a weekly basis.
- D. For testing/inspection agency services, refer to Section 1, Part 3, Article 1.3.4 of the General Conditions.

PART 2 - PRODUCT

2.1 STEEL DECK

- A. Deck shall be manufactured from 20-gauge steel conforming to ASTM A 1008/A1008M Grade C or A653/A653M Grade A and having a minimum yield strength of 33,000 psi.
- B. The deck shall have integral ribs, all continuous and complete in cross section, spaced not more than 6-1/2" o.c. Ribs shall be formed to a depth of not less than 1-1/2". Ribs shall be not less than 1-3/4" wide at point of bearing.
- C. Sheets shall be so fabricated as to permit telescoping end laps not less than 2-1/2" long, made on structural supports. Side laps shall be of the interlocking type or have other provisions for fastening.
- D. All sheets of deck furnished shall be furnished in lengths to match spacing of supports and be free of imperfections, and rust spots. Defective sheets shall be replaced.
- E. Deck sheets shall be either hot dipped galvanized with 1-1/4 oz. Zinc coating, or they shall be scoured and phosphate coated and then painted with a sprayed on, oven baked primer. Galvanizing shall meet ASTM A653/A653M, G 90.
- F. Compute the properties of metal roof deck section on the basis of the effective design width as limited by the provisions of the AISI Specifications. Provide not less than the metal deck section properties shown on the drawings, including section modulus and moment of inertia per foot of width, but not less than requirements of FMI 28.

2.2 WELDING WASHERS

- A. Welding washers shall be standard cut washers not less than 1" in diameter and 1/16" thick.
- B. Welding washers may be omitted for the 22 gauge deck provided the contractor submits a letter from the testing company certifying all of the puddle welds.

2.3 PROVISION FOR OPENINGS

- A. Roof opening over 12" square shall be framed with 4" x 3" x 1/4" angles with vertical long leg down, except where called for otherwise on plans.
- B. Vertical legs of angles shall be coped for field welding to steel joists or to other angles.
- C. Provide roof framing as in "A" for all roof drains.

PART 3 - EXECUTION

3.1 ERECTION

- A. Bundles of decking shall not be placed on steel joist prior to placement as the joist must be laterally stayed by the deck before they can develop their design loads. Bundles one stack high may be placed along beam lines after joists are welded in place and bridged.
- B. The sheets shall be erected true to alignment, placed evenly, and matched at joists.
- C. The deck shall be fastened to structural members by means of electric arc welding through steel washers. Minimum diameter puddle weld of 5/8" diameter. Weld shall be spaced not more than 6" o.c. at all bearing points, unless otherwise shown.
- D. When completed the deck shall form a flat and continuous surface for the complete support of all insulating and roofing materials.
- E. During erection coordination with other trades shall prevail, and openings and special conditions shall be provided as called for by plans and specifications.
- F. If side laps are of the interlocking type, they shall be button punched. If side laps are not of the interlocking type, they shall be fastened with self tapping screws, minimum size #10. Maximum spacing shall be 6" o.c. unless otherwise shown.
- G. Deck shall bear a minimum of 2" on supports.
- H. Insulation supports shall be provided where rib openings in the top surface of roof decking occur adjacent to edges and openings. Weld closure strips into position.

3.2 PRECAUTION

- A. After decking is welded to supporting members, construction loads not exceeding 20 pounds per square foot may be placed on the deck.

3.3 FIELD PAINTING

- A. After erection, all welds shall be touched up with a rust inhibitive paint.
- B. After notice, the Architect or his representative shall have an opportunity to inspect and pass upon the placement of the decking before insulation is placed thereon. Inspection of the roof deck shall also include the roofing applicator.

END OF SECTION 05 3000

2020, Jericho Design Group, LLC. These drawings are protected by the copyright laws of the United States. These drawings or any part thereof may not be used for any purpose or reproduced in any form or by any means without the written consent of Doug Shaw.

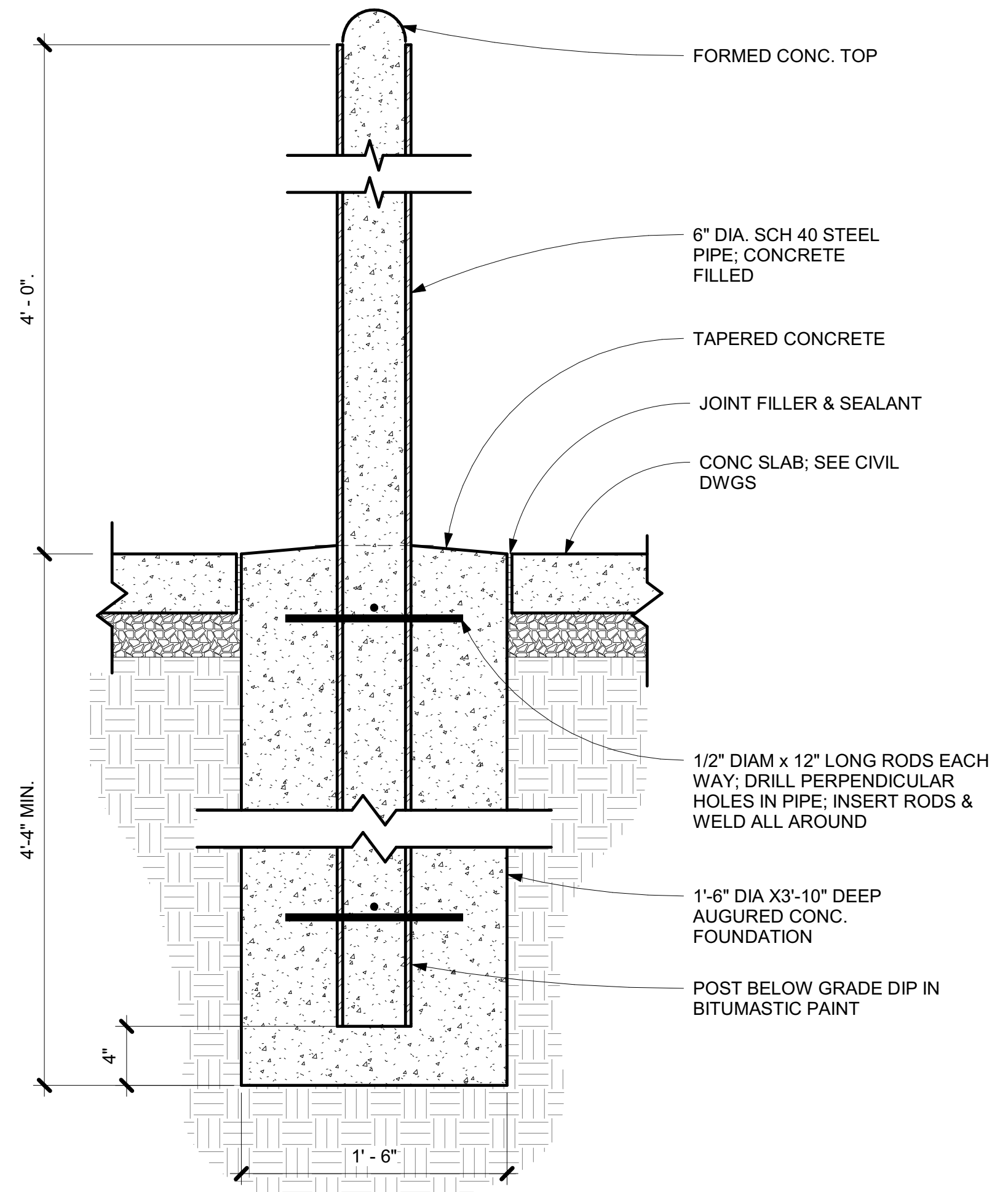

8 TYP. BOLLARD DETAIL
SCALE: 1 1/2" = 1'-0"

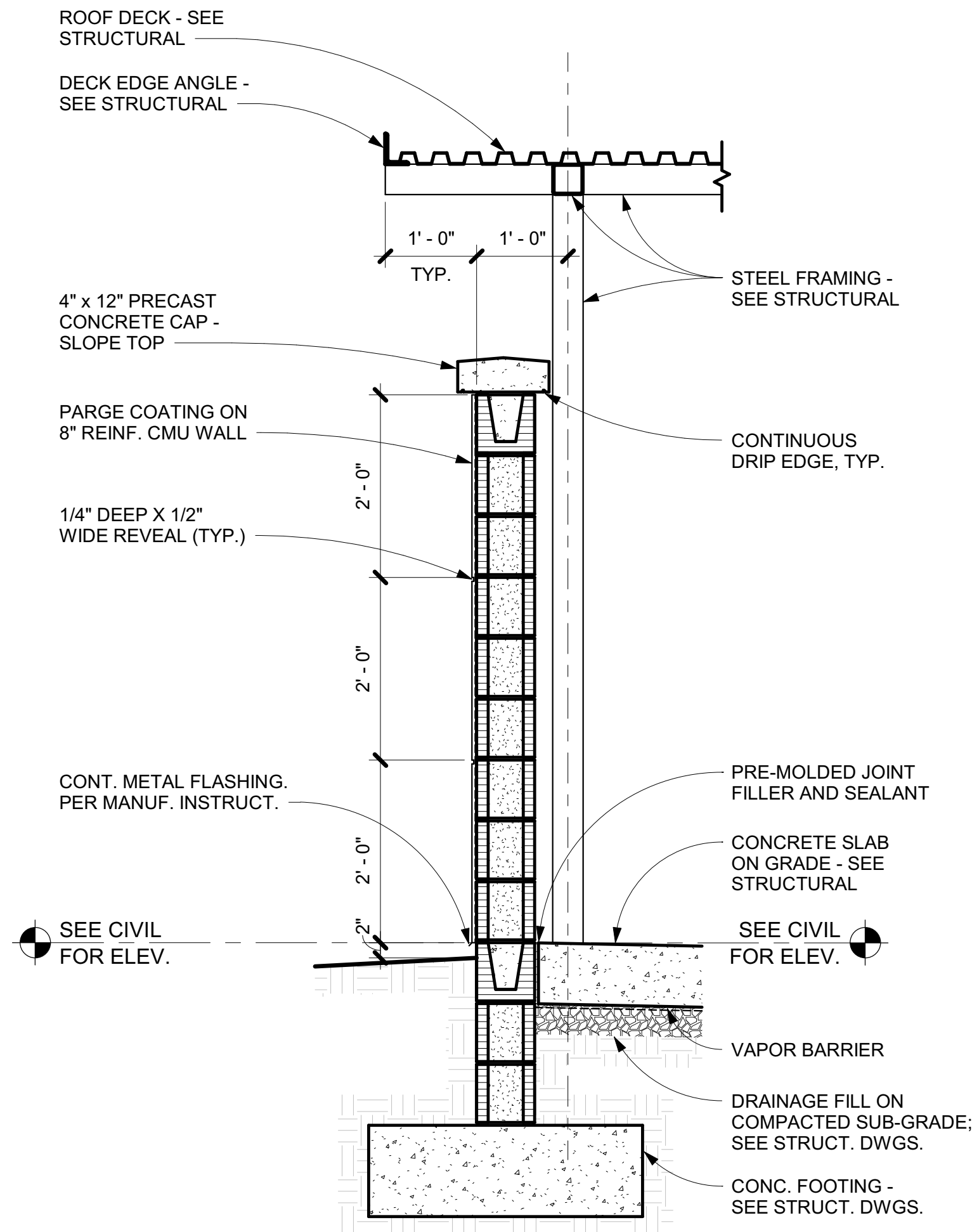

7 DUMPSTER SECTION
SCALE: 3/4" = 1'-0"

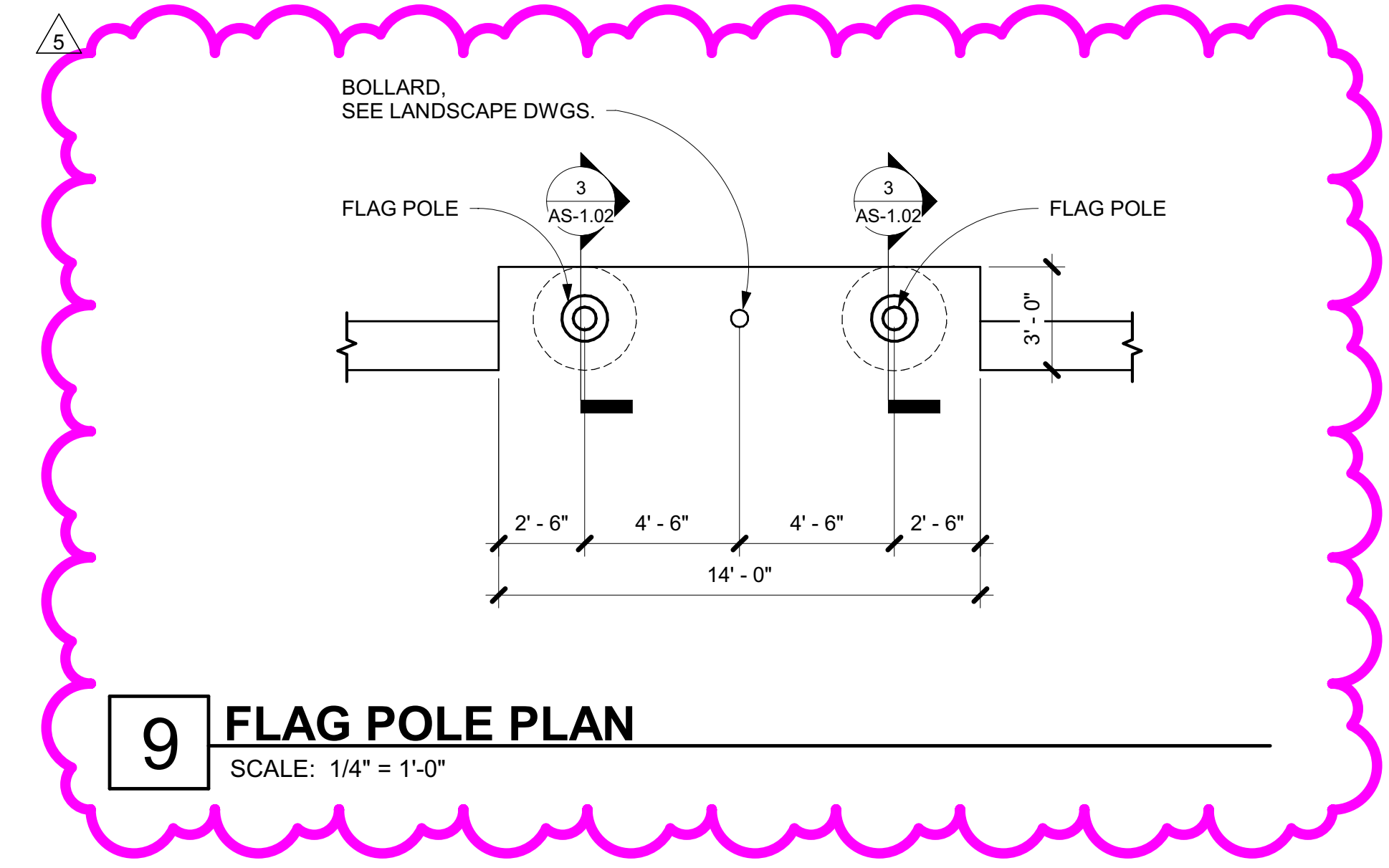

9 FLAG POLE PLAN
SCALE: 1/4" = 1'-0"

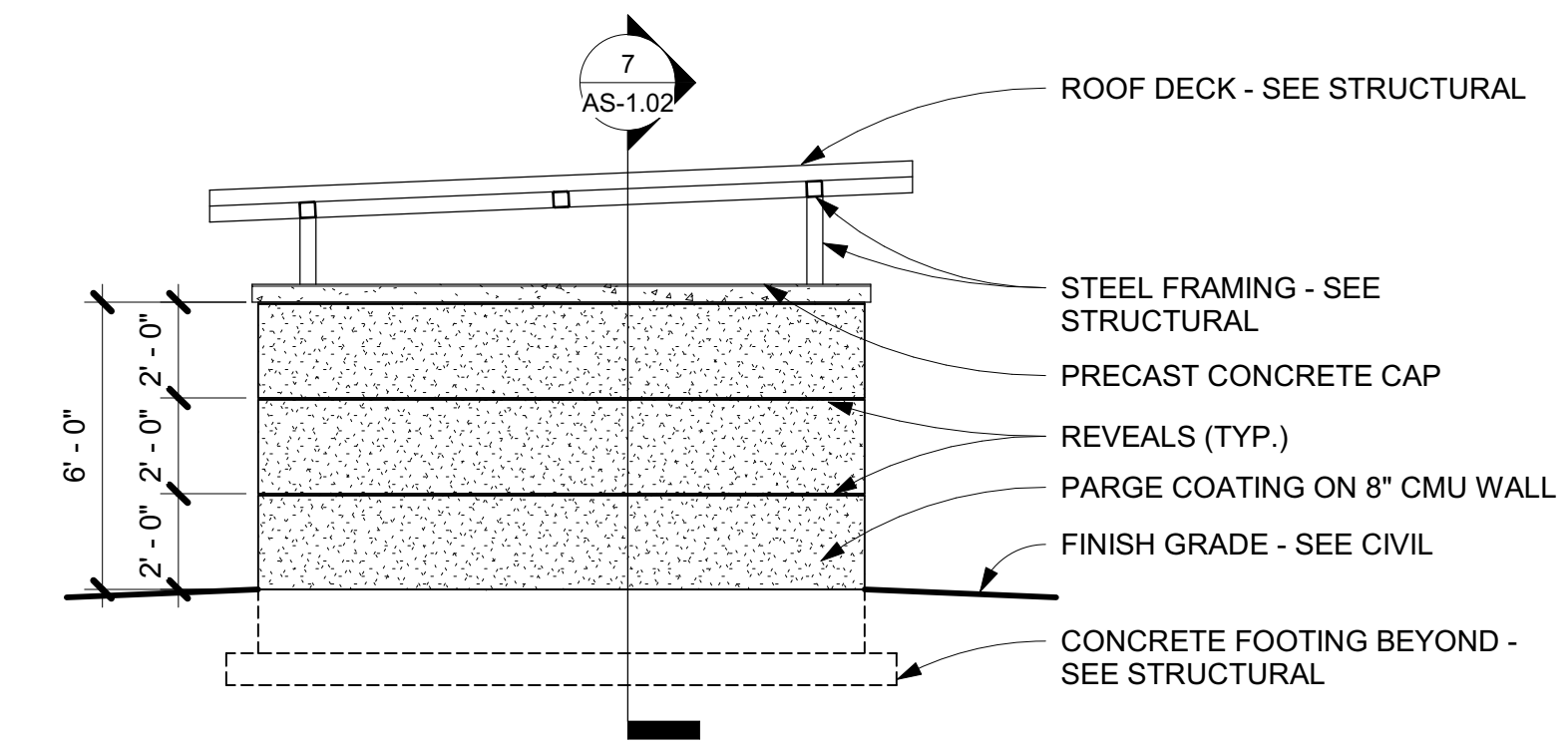

6 DUMPSTER ELEVATION
SCALE: 1/4" = 1'-0"

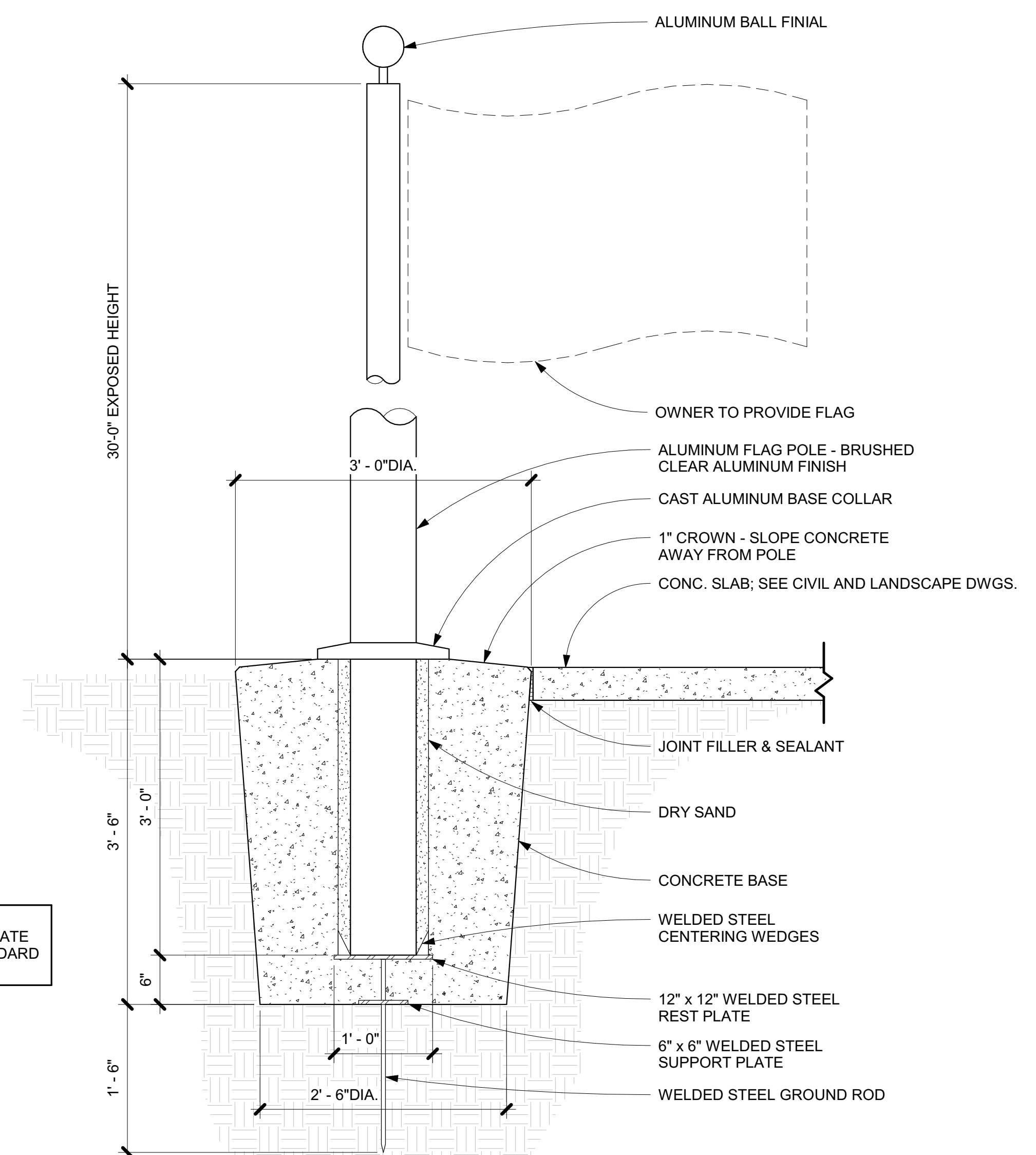

NOTE: CC TO COORDINATE WITH MFR STANDARD DETAILS

3 FLAG POLE DETAIL
SCALE: 1" = 1'-0"

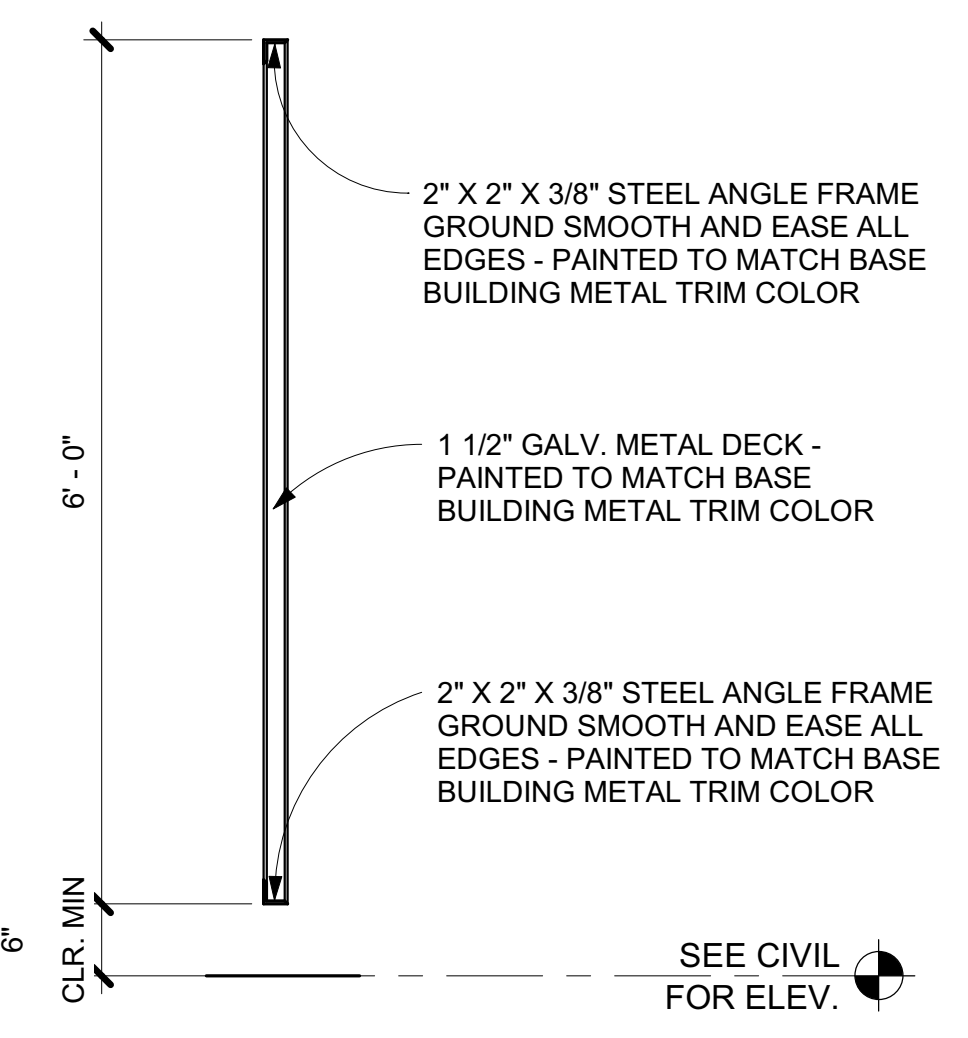

5 GATE SECTION DETAIL
SCALE: 3/4" = 1'-0"

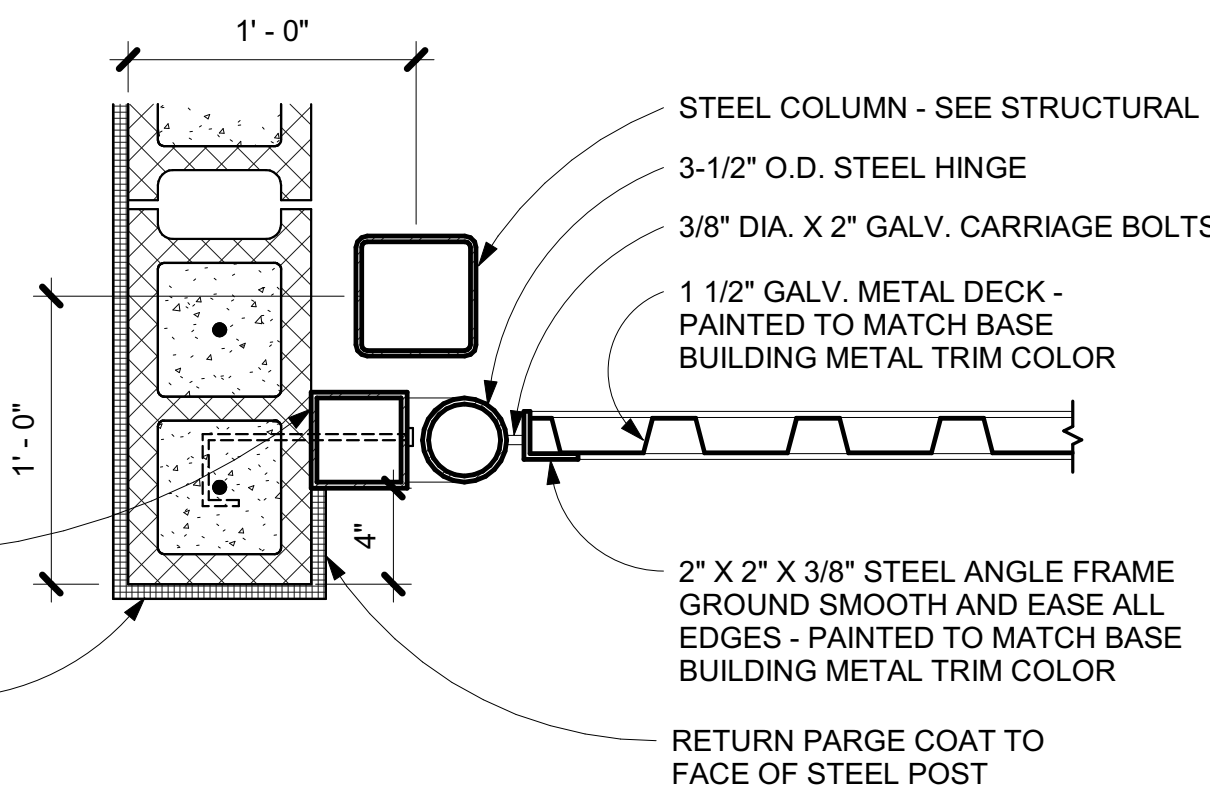

2 DUMPSTER GATE JAMB
SCALE: 1 1/2" = 1'-0"

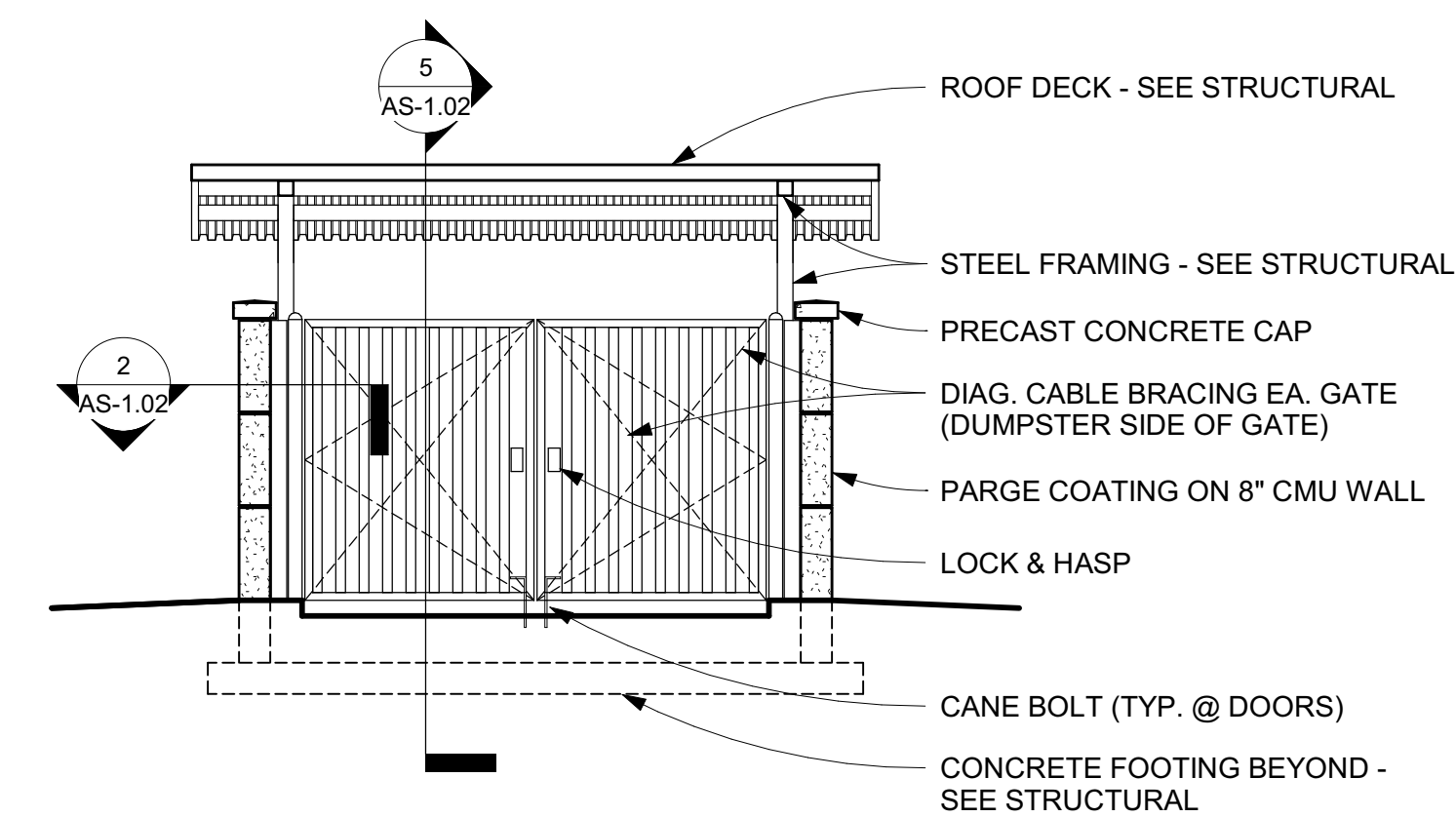

4 DUMPSTER GATE ELEVATION
SCALE: 1/4" = 1'-0"

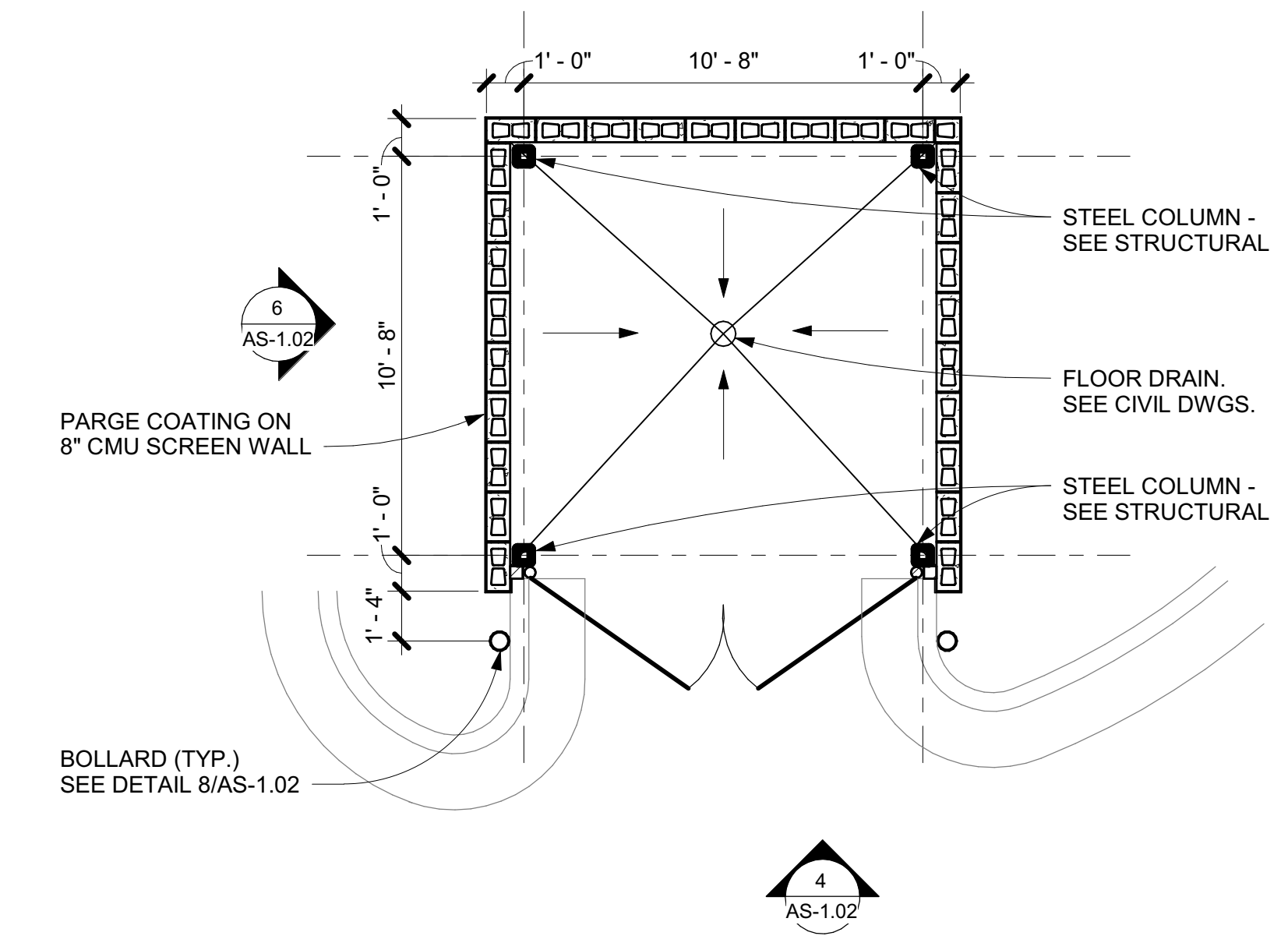

1 DUMPSTER FLOOR PLAN
SCALE: 1/4" = 1'-0"



102 Mary Alice Park Road, Suite 103
Cumming, GA 30040



Kimley Horn
Expect More. Experience Better.

Nannis & Associates
STRUCTURAL ENGINEERS
218 South Hill Street | Buford, GA 30518
(p) 770-614-6114 | (f) 678-765-7966



FORSYTH COUNTY JUVENILE COURT BUILDING

FORSYTH COUNTY BOARD OF COMMISSIONERS

875 LANIER 400 PARKWAY
CUMMING, GA 30040

PRINT RECORD		
No.	DATE	DESCRIPTION
03/16/2020	03/16/2020	Release for Bid and Permit
05/08/2020	05/08/2020	Release for Bid
07/10/2020	07/10/2020	Addendum 5

Drawn By: [Blank] Checked By: [Blank]
Date: 03/18/2020 Job No.: 19059
Sheet Title: ARCHITECTURAL SITE DETAILS

Sheet No.: **AS-1.02**
RELEASED FOR CONSTRUCTION

7/9/2020 2:34:51 PM
C:\Users\dfizpatrick\Documents\19059 DG FOOO_JUV_ARCH_RVT19_dflzpatrick696\JM.rvt