



Forsyth County Procurement

Greg Bridges, Procurement Agent III

December 9, 2020

ADDENDUM #1

Bid No. 20-171-5211

For: Providing all materials, equipment and labor for the Restroom and Bathhouse Renovations at Shady Grove Campground, Charleston Park, and Young Deer Creek Park.

This addendum supersedes and supplements all portions of the bidding documents and becomes part of the contract documents for the above-referenced project.

Where any item called for in the specifications or indicated on the drawings is supplemented hereby, the original requirements shall remain in effect.

Where any original item is amended, voided or superseded hereby, the provision of such item not so specifically amended, voided or superseded shall remain in effect.

Clarification on Bidder Questions:

- 1. Q: Is a General Contractors License a requirement for this project?**
A: No
- 2. Q: Will the Contractor be allowed to have access to the Campground Gate?**
A: Yes, once Notice to Process issued, contractor will be given a 4-digit special use code for the duration of project.
- 3. Q: Are the exterior lights at the doors to be replaced at the 2 Restroom locations?**
A: No
- 4. Q: Are the Add Alternates the combined cost of all three (3) Bathhouse roofs to be repaired or replaced?**
A: Yes

5. Q: The PM mentioned yesterday at the pre-bid meeting the need for heaters at all RRs and bathhouses. She mentioned there being a designated location for those heaters on the plans. Are you able to shine some light on the heater locations?
A: *The heaters will be placed in the plumbing room at Charleston & Young Deer Parks to protect the piping from freezing.*
6. Q: Is there a painting scope of this project?
A: *Only to touch up walls at Charleston & Young Deer Parks interior walls after new fixtures are replaced.*
7. Q: The floors are called to be acid washed and sealed. Is there a spec for the sealant we need to use?
A: *A professional strength formulation that helps to remove tough coatings lacquers varnishes sealers paints and epoxy grout haze from surfaces. A product that effectively dissolves heavy wax and helps to remove deep-set stains and heavy grease buildup.
A professional penetrating sealer designed for the protection of porous surfaces. It must form an invisible barrier that is resistant to moisture and stains while allowing vapor to escape and will not alter the natural look of the tile.*
8. Q: The roofing scope calls for a tear off and replacement of a new asphalt shingled roof, does this apply to Charleston Park and Young Deer? Are we replacing roofs for these two locations at all?
A: *No. Roof replacements are only for Shady Grove Campground bathhouses A, B, & C.*
9. Q: The steel stud framing scope is very vague, what walls does this apply to and to what extent?
A: *This scope only applies to Charleston and Young Deer parks for the stabilization of the walls and the new fixtures being mounted on / through the walls.*
10. Q: There is no spec or model for the lavatories in the bid document. Is the standard vitreous china as for the water closets?
A: *The sinks and toilets are to be standard white vitreous china.*
11. Q: The existing lights in Charleston Park and Young Deer Creek Park are wall mounted fixtures, but spec requires ceiling mounted LED lights. Do we remove the wall fixtures and install ceiling lights? How many of them are required in each restroom?
A: *The product that is the BOD is a surface mounted fixture, see attachment. Each restroom has 2 lights, so 4 total per park and 8 overall.*

12.Q: The bid documents indicate that the Liquidated damages of \$500/day. What is the project completion date?

A: *Bathhouses A, B, & C should be completed by March 5, 2021. Charleston and Young Deer Park Restrooms should be completed by May 1, 2021.*

13.Q: Do we need to include the design work for Forsyth County Permit application in our bid?

A: *You will need to provide the required documents for the Permit and Plan Review process for the County.*

14.Q: If the intent is to bring the facilities up to code, are you open to changing the toilet layouts or reducing the number of toilets/urinals? (We can provide a layout along with the bid.)

A: *Keep with the original plan.*

15.Q: Should we include any ADA site work access improvements in our proposal?

A: *There will be no sitework for this project.*

Attachment for Question 11:

4FT Vaportight Luminaire

40W

FEATURES ///

ENVIRONMENTALLY FRIENDLY, ENERGY EFFICIENT

- The Etrenzik Vaportight LED series delivers up to 5,800 lumens while achieving up to 145 lumens per watt
- Direct/indirect distribution of soft light creates superior brightness control and balanced light
- Available in wide range of color temperatures with 0-10V dimming
- No harmful ultraviolet or infrared wavelengths
- Contains no lead or mercury

PRODUCT SPECIFICATIONS ///

Voltage:	120/277
Color:	Stark White
CRI:	83
Width:	6.75 in.
Finish:	White
Life Hours:	50,000
Lumens (Initial):	5,800
Mounting:	Surface Mount/Hardware Included
Weight:	7 lbs.
RoHS:	Compliant
IP Rating:	IP-65
Warranty:	5 Years



DIMENSIONS ///

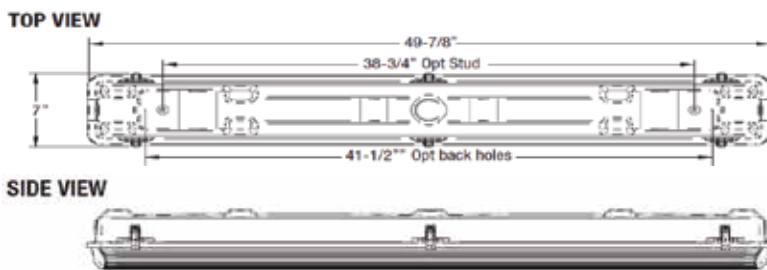

EXPLODED VIEW

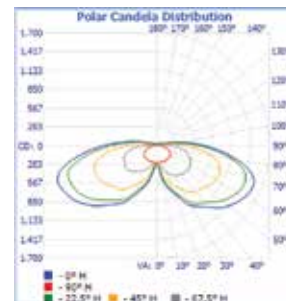
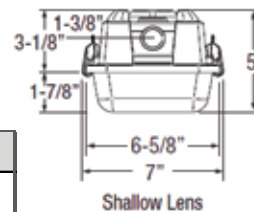
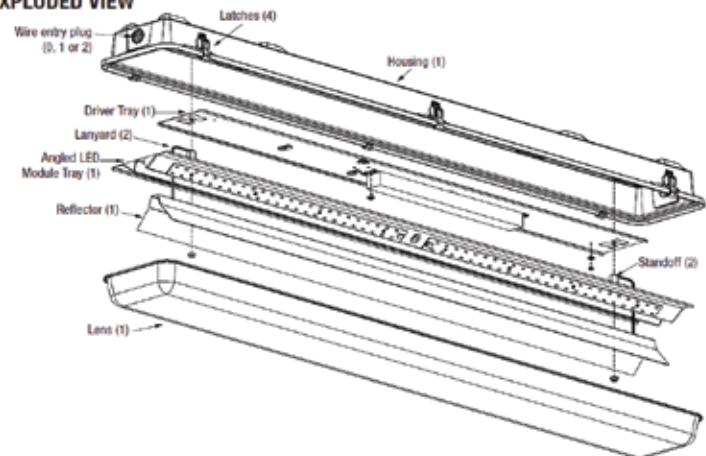

ORDERING INFORMATION ///

Example = EVPT4-4050-PWL

Category	Wattage	Color Temperature	Options
EVPT4	40W - 40W	50K - 5000K	WG - Wire Guard PWL - Acrylic Lens

CONTACT

Etrenzik Manufacturing, Inc.
 (866) 267-7047 office • (678) 807-1900 Fax
 Info@etrenzik.com

169 Creamer Drive
 Alpharetta, GA 30004
 www.EtrenzikMFG.com